



PROFTECH
SPÓŁKA Z O.O.



AB 994

*Research laboratory
accredited by PCA, Nr AB
994*

Scopes of accreditation:

- concentration and mass measurements of flow of fine particles
- measurements of concentration and mass flow of SO₂, NO_x, CO
- concentration measurements of CO₂, O₂
- concentration and mass flow measurements of OWO
- sampling for mass concentration determination of PCDD/PDF and dioxin type PCB
- sampling for concentration determination of (As; Cd; Cr; Co; Cu; Mn; Ni; Pb; Sb; Ti; V)
- sampling for concentration determination of Hg
- sampling and determination of concentration and mass flow of HCl
- sampling and determination of concentration and mass flow of HF
- sampling for determining the concentration of individual gaseous organic compounds
- calibration of Automated Monitoring systems,
- QAL2 procedure
- annual performance test of Automated Monitoring Systems, AST procedure
- noise measurement from machinery, installations and industrial plants

Chorzów, July 23th 2024
Our ref. No.: PW/61/07/24

Report No PW/61/07/24

on concentration measurements of PCDDs/PCDFs and dioxins-like PCBs emitted into environment from flue gas channel located at UAB GREN KLAIPEDA, Kretainio g. 3 LT-94103, Klaipeda, Lithuania.

Client name and address:

UAB "GREN KLAIPEDA"

Kretainio g. 3,
LT-94103 Klaipeda

Developed by:

mgr Grzegorz Bortel

Calculation and data transfer checked by:

inż. Dariusz Guja

Verified by:

inż. Dariusz Guja

Copy number: 1/3.....

DYREKTOR
inż. Dariusz Guja

ul. Kurta Aldera 44
41-506 Chorzów
tel/fax: 0 32 247 37 24

www.proftech.com.pl
e-mail: proftech@proftech.com.pl

NIP: 627 252 46 31
KRS: 0000773369

bank account : PKO BANK POLSKI S.A. O/Katowice : IBAN PL62 1440 1172 0000 0000 0353 4332

Test Report No PW/61/07/24

List of contents:

- 1. PURPOSE AND SCOPE OF THE REPORT**
- 2. BASIS OF MEASUREMENTS EXECUTION**
- 3. MEASUREMENT TEAM**
- 4. MEASUREMENT RESULTS SUMMARY**
- 5. DESCRIPTION OF THE MEASUREMENT METHOD**
- 6. MEASUREMENT RESULTS**
- 7. MEASUREMENT DEVICES**
- 8. ANALYSIS RESULTS**
- 9. CERTIFICATE OF ACCREDITATION**
- 10. MEASUREMENT PLANE SCHEME**

Test Report No PW/61/07/24**1. PURPOSE AND SCOPE OF THE REPORT**

Purpose of executed measurements was to determine the concentration and emission of *PCDDs/PCDFs and dioxins-like PCBs* emitted to environment from flue gas channel located at UAB GREN KLAIPEDA, Kretainio g. 3 LT-94103, Klaipeda, Lithuania

Measurements range:

- PCDD/DF emission and concentration,
- PCB emission and concentration.

The measurements were carried out in accordance with the sampling plan and the described sampling methods.

Operating parameters of the technological installation was obtained from the customer's representative.

2. BASIS OF MEASUREMENTS EXECUTION

The measurements were taken according to the Purchase Order dated June 06th 2024, our reference number PP/28/06/24.

3. MEASUREMENT TEAM

The measurements taken on June 06 - 07th 2023 were executed by the following team:

- Grzegorz Bortel specialist- measurement team leader,
- Karol Sodo specialist,
- Przemysław Zubel specialist.

4. MEASUREMENT RESULTS SUMMARY

Below are presented measurement results summary, full measurement results are presented in chapter no 6, at page 8.

Concentration of the substance in the gas in the reference conditions O2 ref. 11%	PCDDF	ng/m3	0,022
	PCB	ng/m3	0,0006
Emission limits	PCDDF	ng/m3	0,06

Test Report No PW/61/07/24

5. DESCRIPTION OF THE MEASUREMENT METHOD**Measurement of the gas volumetric flow**

The flow rate was determined according to ISO Standard PN-EN ISO 16911-1:2013 „Stationary source emissions - Manual and automatic determination of velocity and volume flow rate in ducts - Part 1: Manual reference method". Gravimetric dust monitor type Megasystem APIS X-1 and type "S" Pitot tube were used for the measurements. Measurement is accredited.

Accreditation range: differential pressure: > 5 Pa

Measurement O₂ content

The concentration of O₂ was determined using gas analyzer HORIBA PG-350E-EU equipped with testing probe 1750 mm long. The measurements were taken according to the procedure described in measurement unit as well as to Polish Standard PN-EN 14789:2017 "Stationary source emissions - Determination of volume concentration of oxygen O₂ - Reference method - Paramagnetism". Measurement is accredited.

Accreditation range: O₂ content: 3-21%

Measurement CO₂ content

The concentration of CO₂ was determined using gas analyzer HORIBA PG-350E-EU equipped with testing probe 1750 mm long. The measurements were taken according to the procedure described in measurement unit as well as to Polish Standard PN-ISO 10396:2001 "Stationary Source Emissions - Sampling For The Automated Determination Of Gas Concentrations ". Measurement is accredited.

Accreditation range: CO₂ content: 0,1-20%

Measurement moisture content

Moisture content was determined using condensation-absorption method. The measurements were taken according to Polish Standard PN-EN 14790:2017. Measurement is accredited.

Accreditation range: H₂O content: 29-250 g/m³

Test Report No PW/61/07/24

PCDDs/PCDFs and dioxins-like PCBs sampling and determination

PCDD/DF samples were taken according to the requirements of Polish Standard PN-EN 1948-1:2006 „ Stationary source emissions - Determination of mass concentration of PCDDs/PCDFs and dioxin-type PCBs - Part 1: Sampling of PCDDs/PCDFs”.

PCB samples were taken according to the requirements of Polish Standard PN-EN 1948-4:2014-03 „ Stationary source emissions - Determination of mass concentration of PCDDs/PCDFs and dioxin-type PCBs - Part 4: Sampling and analysis dioxin-like PCBs”.

The three stages of PCDD/DF and PCBs concentration and emission determination:

Stage I - sampling

For the determination of mass concentration of PCDD/DF and PCBs proper sampling plays important role that affects following stages of the testing. The sampling were performed by means of the filtration and condensation method using PCDD/DF and PCBs sampling system conformed to European Standard PN-EN 1948-1:2006 and PN-EN 1948-4:2014-03.

The following page shows the schematic diagram of the sampling system.

Stage II - laboratory analysis

The samples were analysed at the ALS Czech Republic, s.r.o accredited laboratory following the CSN EN 1948-2,3,4 methodology: The determination of polychlorinated dibenzo-p-dioxine, dibenzofurans in emission samples with the method of isotop dillution using HRGC/HRMS.

The dioxin and furans analyses were conducted at the ALS Czech Republic, s.r.o. Laboratory, specifically accredited for the test by the Český Institut Pro Akreditaci, o.p.s. , Nr L 1163.

Stage III - development and the results and discussion

The last stage includes results collection from the previous stages, emission calculation and PCDD/DF and PCBs concentration as well as comparison to the standards in force.

Test Report No PW/61/07/24

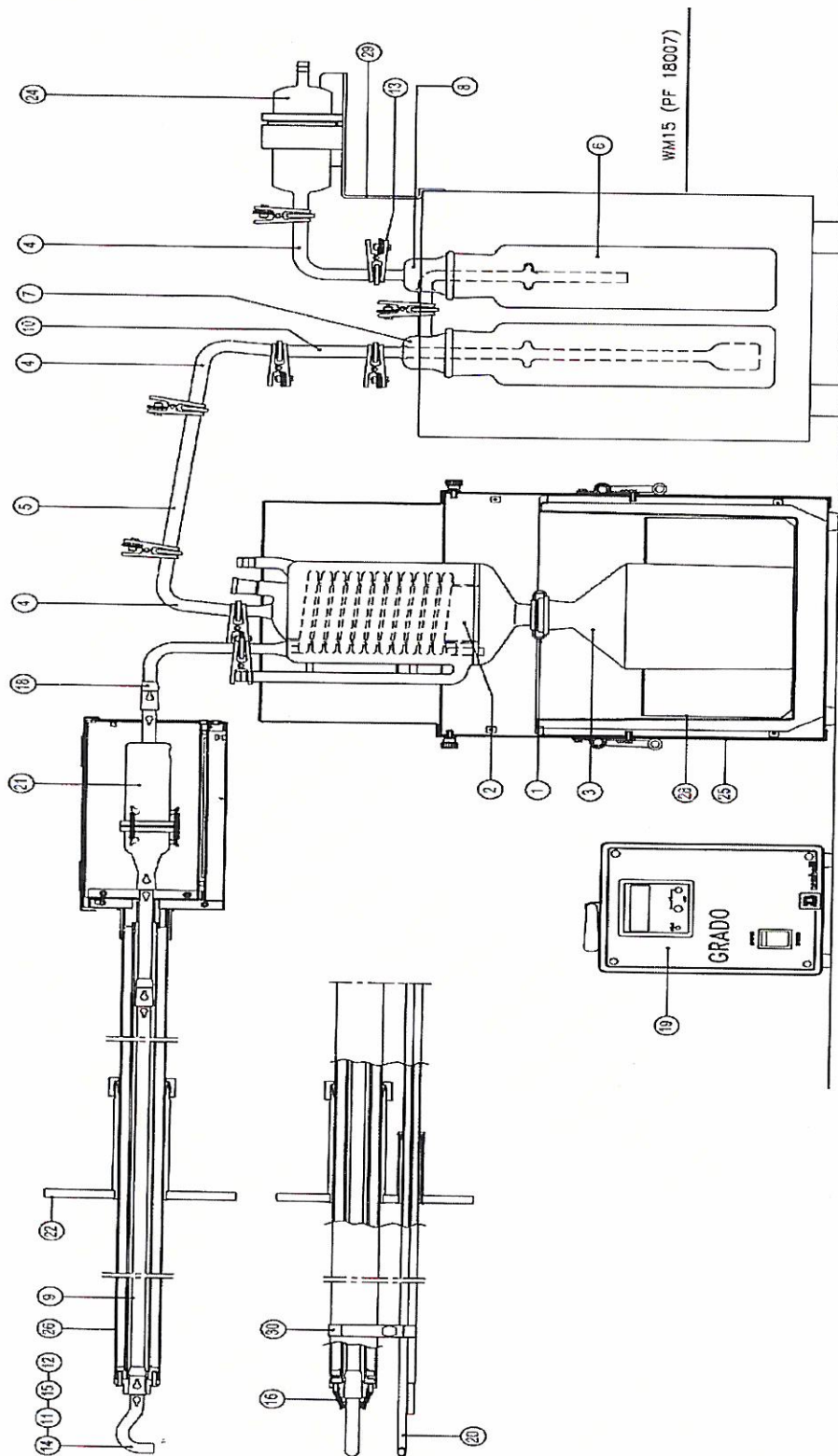

- Opis:
- 1. ferrule
 - 2. cooler
 - 3. condensation pot
 - 4,18. aspiration path - elbows
 - 5,10. aspiration path - tubes
 - 6-8. scrubbers
 - 9. aspiration path - probe tube
 - 11,12,14,15. - aspiration endings
 - 13. clamp
 - 16. holding springs
 - 17. aspiration controller
 - 19. temperature controller
 - 20. Pitot tube „S” - type
 - 21. filter casing
 - 22. yoke
 - 23. cooler coil
 - 24. gas dryer
 - 25. cooler probe
 - 26. heated probe
 - 27.30. support
 - 28. cooler coil

Test Report No PW/61/07/24

6. MEASUREMENT RESULTS

Test Report No PW/61/07/24

- 1) Plant or unit name: **Combined Heat and Power Plant¹⁾**
- 2) Flue gases cleaning unit: **ALSTOM NID flue gas cleaning solution (bag filters, activate carbon, ammonia solution, hydrated lime)¹⁾**
- 3) Emission source load during measurements: **89 MW**
- 4) Fuel type or material mass flow in process: **40% municipal waste, 60% industrial waste; 33 t/h**
- 5) Location of sampling and measurements: **in duct, after flue gases cleaning unit**

Measurement reference number		06/07-06-01		X	X	
Date of measurement		06-07.06.2024				
Measurement time range		21:16-03:17				
Scope of test		Unit	Results	Uncertainty +/-	Method	
Meteorological conditions	Atmospheric pressure		hPa	1013,7	X	
	Air temperature		oC	14		
Measurement plane	Diameter		m	2,20		
	Area		m ²	3,4619		
Stack gas parameters	Temperature		oC	57		
	Static pressure		Pa	-26		
	Differential pressure		Pa	240		
	Gas moistness grade X		kg/kg	0,124		
	Average velocity		m/s	16,6		0,1
	Chemical composition	O ₂	%	7,7		0,2
		CO ₂	%	11,6	0,4	PN-ISO 10396:2001
	Wet gas density during testing		kg/m ³	1,037	X	PN-EN 14790:2017
Gas density in normal conditions		kg/m ³ N	1,253	PN-EN 14790:2017		
Gas density in conventional conditions		kg/m ³ U	1,347	PN-EN 14790:2017		
Concentration in the gas at measurement conditions	PCDDF*		ng/m ³	0,0022	0,0007	PN-EN 1948:2006
	PCB*			0,0006	0,0002	PN-EN 1948-4:2014-03
Concentration in the gas at normal conditions	PCDDF*		ng/m ³ N	0,0022	0,0007	PN-EN 1948:2006
	PCB*			0,0006	0,0002	PN-EN 1948-4:2014-03
Concentration of the substance in the gas in the standard conditions	PCDDF*		ng/m ³ U	0,0029	0,0009	PN-EN 1948:2006
	PCB*			0,0008	0,0003	PN-EN 1948-4:2014-03
Concentration of the substance in the gas in the reference conditions O ₂ ref. 11%	PCDDF*		ng/m ³ U	0,0022	0,0007	PN-EN 1948:2006
	PCB*			0,0006	0,0002	PN-EN 1948-4:2014-03
Gas volume flow	measurement conditions		m ³ /h	226779	3766	X
	normal conditions		m ³ N/h	187583	3115	
	conventional conditions		m ³ U/h	155256	2578	
	conventional conditions O ₂ ref. 11%		m ³ U/h	206490	5100	
The emission obtained by measuring	PCDDF*		ng/h	450,24	142,44	PN-EN 1948:2006
	PCB*			124,20	39,29	PN-EN 1948-4:2014-03
Emission limits	PCDDF*		ng/m ³ U	0,06	X	X
Transgresssion	PCDDF*		ng/m ³ U	-		

*- the results obtained from the subcontractor (accredited)
¹⁾-information obtained from the client

Test Report No PW/61/07/24Notes:

Normal conditions designate the temperature of 273 K and pressure of 101,3kPa, defining normal cubic meter m³N. The conventional conditions designate the temperature of 273K, pressure of 101,3 kPa and dry gases (steam contents less than 5 g/kg of flue gas), defining conventional cubic meter, m³U

The specified expanded uncertainty comes from standard uncertainty multiplied by expansion coefficient k = 2, which provides 95% level of confidence for normal distribution. Uncertainty takes into account the sampling and analysis.

Registry of samples delivered to the laboratory: P/47/06/24, P/48/07/24
Date of delivery to the laboratory: 11.06.2024
Date of analysis: 11.06 - 26.06.2024

Field blanks:

ID/ number of sample	Type of substance	The criterion of the blank [ng/m ³] 11%O ₂	The value of the blank [ng/m ³] 11% O ₂	Result [+/-]
P/48/07/24	PCDD/DF	0,006	< 0,0013	+
	PCB	n/a	< 0,0005	+

Work parameters of measurement system:**PCDD/DF (PN-EN 1948:2006) and PCB (PN-EN 1948-4+A1:2013)::**

sampling method: condensation - adsorption method
filter parameters: 19 x 90 mm, filter efficiency: 99,998 %
sampling train: 2 measurement axis
oxygen reference : 11 %
time of dioxins and furans measurement: 21:16 – 03:17 (360,1 min)
nozzle diameter: 6 mm
probe temperature: 118 °C
scrubbers temperature 4 °C
aspired gas volume 7,394 m³
average sampling flow 20,5 l/min
isokinetic ratio: 98,4 %
leak test: + / +
gas meter temperature 20,9 °C
gas meter pressure 0 bar
spiking pattern: filter surface
absorption solution: 100 ml H₂O dest. + 50 ml 2-etoksyetanol
recovery: 93 % ¹³C₁₂-1,2,3,7,8-PECDF, />50%/
91 % ¹³C₁₂-1,2,3,7,8,9-HxCDF, />50%/
74 % ¹³C₁₂-1,2,3,7,8,9 HpCDF. />50%/
63 % ¹³C₁₂-2,3,4,4'-tetraCB (60), />50%/
55 % ¹³C₁₂-2,3,3',4,5,5'-hexaCB (159). />50%/
PCDD/DF TEQ sample mass: 0,002 ng
PCB TEQ sample mass: 0,0055 ng

Test Report No PW/61/07/24

H₂O (PN-EN 14790:2017)
 sampling train: 2 measurement axis
 sampling equipment: titanium sampling train
 heated probe 2,0 m long
 sampling pump: X1 APIS 0185
 cartridge: PCDDF / moisture measurement set
 number of samplings: 1
 sampling time: 360,1 min
 sampling volume: 20,5 l/min
 H₂O maas: 1150,00 g
 absorption efficiency: 99,5 %

O₂ paramagnetic (PN-EN 14789:2017):
 Range : 0 – 5 % []
 0 – 10 % [X]
 0 – 25 % []
 Calibration gas: O₂ – 8,001% [X] R/07/W
 O₂ – 18,85% [] R/12/W
 N₂ – 99,99% [X] R/17/
 Sampling train: 2 measurement axis
 Sampling time/ average time: 360 min / 1 min

O ₂ concentration measurement (paramagnetic):		HORIBA PG-350E-EU (130/1/AW/21)			
check operation		unit	result	criterion	result +/-
„0” after adjustment, without sampling train		%	0,02	± 0,1 [%]*	+
„0” after adjustment, with sampling train	before measurement	%	0,05	± 0,5 [%]**	+
	after measurement	%	0,06	± 0,5 [%]**	+
„Span” after adjustment with sampling train /standard 8,001 % R/12/W analyzer range 10%/	before measurement	%	8,05	± 0,5 [%]**	+
	after measurement	%	7,99	± 0,5 [%]**	+
	before measurement time T90	%	8,2	> 17,0 [%]	-----
		sec.	31	< 200 sec.	+

Test Report No PW/61/07/24**7. MEASUREMENT DEVICES**

Name of measuring device		X1- Apis PLUS
Type of measuring device		Isokinetic sampler S/N 0185
Certificate	Calibration No	94/54/LA/P/2023 G-73/23-46/23 65/1/T/23
Issued by		PLUM Sp. z o.o. KLEOSIN ZAP BESTWINKA LABOSERWIS Sp. z o.o. KATOWICE
Date of issue the certificate of calibration		27.02.2023 r. 23.02.2023 r. 02.03.2023 r.
Expiration date of the certificate of calibration		-

Name of measuring device		HORIBA
Type of measuring device		PG-350E-EU
Certificate	Calibration No	130/1/AW/21
Issued by		Laboserwis Sp. z o.o. Katowice
Date of issue the certificate of calibration		28.05.2021
Expiration date of the certificate of calibration		-

Test Report No PW/61/07/24

8. ANALYSIS RESULTS

Attachment no. 1 to the Certificate of Analysis for work order PR2469525

Sample: P/47/06/24

ALS SAMPLE ID: PR2469525/ 001

Measurement results PCDD/Fs:

Sample: P/47/06/24		Final extract [µl]: 60			
		Injection volume [µl]: 4			
		Acquisition date [d.m.y h:m]: 18.6.24 5:42			
2,3,7,8-PCDD/Fs	Result [ng/sample]	Limit of Detection [ng/sample]	Limit of Quantification [ng/sample]	¹ I-TEFs	I-TEQ Upperbound [ng/sample]
2,3,7,8-TCDD	< 0.0029	0.0029	0.0057	1	0.0029
1,2,3,7,8-PeCDD	< 0.0038	0.0038	0.0075	0.5	0.0019
1,2,3,4,7,8-HxCDD	< 0.0061	0.0061	0.012	0.1	0.00061
1,2,3,6,7,8-HxCDD	< 0.0061	0.0061	0.012	0.1	0.00061
1,2,3,7,8,9-HxCDD	< 0.0061	0.0061	0.012	0.1	0.00061
1,2,3,4,6,7,8-HpCDD	< 0.02	0.02	0.04	0.01	0.0002
OCDD	< 0.021	0.021	0.042	0.001	0.000021
2,3,7,8-TCDF	< 0.011	0.0057	0.011	0.1	0.0011
1,2,3,7,8-PeCDF	< 0.014	0.007	0.014	0.05	0.0007
2,3,4,7,8-PeCDF	< 0.014	0.007	0.014	0.5	0.007
1,2,3,4,7,8-HxCDF	< 0.013	0.0065	0.013	0.1	0.0013
1,2,3,6,7,8-HxCDF	< 0.013	0.0065	0.013	0.1	0.0013
1,2,3,7,8,9-HxCDF	< 0.0065	0.0065	0.013	0.1	0.00065
2,3,4,6,7,8-HxCDF	< 0.013	0.0065	0.013	0.1	0.0013
1,2,3,4,6,7,8-HpCDF	< 0.016	0.0079	0.016	0.01	0.00016
1,2,3,4,7,8,9-HpCDF	< 0.0079	0.0079	0.016	0.01	0.000079
OCDF	< 0.015	0.015	0.031	0.001	0.000015
I-TEQ from quantified 2,3,7,8-PCDD/Fs - "Lowerbound"					0
I-TEQ from 2,3,7,8-PCDD/Fs - "Mediumbound"					0.01
Maximum possible I-TEQ - "Upperbound"					0.02
PCDDs	Result [ng/sample]	PCDFs	Result [ng/sample]		
Tetra-CDDs	< 0.063	Tetra-CDFs	0.51		
Penta-CDDs	< 0.053	Penta-CDFs	< 0.2		
Hexa-CDDs	< 0.061	Hexa-CDFs	< 0.1		
Hepta-CDDs	< 0.04	Hepta-CDFs	< 0.032		
OCDD	< 0.021	OCDF	< 0.015		

¹I-TEF according to NATO.

Limits of quantification are defined as double of the detection limits.

The limit of detection is defined as the amount of analyte producing a signal with S/N≥3.

The value of the detection limit is mentioned as the actual value at the acquisition date.

Measurement uncertainty is expressed as a double (k=2) relative standard deviation (RSD%), and corresponds to 95% confidence interval.

Estimation of uncertainty of each 2,3,7,8-PCDD/F congener is 30% and total I-TEQ is 20%.

These values were ensured by analyses of certified reference material under conditions of internal reproducibility.

Results marked with "<" are below limit of detection or quantification.

"Lowerbound" and "Upperbound" are levels defined in Regulation 2017/644 and EN 1948-4.

"Mediumbound" is levels defined in Regulation 2017/644.

Test Report No PW/61/07/24

Attachment no. 1 to the Certificate of Analysis for work order PR2469525

Sample:

P/47/06/24

Standards recovery:

Sample:		P/47/06/24			
		Final extract [µl]:		60	
		Injection volume [µl]:		4	
		Acquisition date [d.m.y h:m]:		18.6.24 5:42	
Extraction standard	Recovery [%]	Acceptable range [%]		Accept. rec. with respect to	
		Basic	Extended	basic range	extended range
PCDDs					
13C12 - 2,3,7,8-TCDD	97	50 - 130	30 - 150	YES	-
13C12 - 1,2,3,7,8-PeCDD	56	50 - 130	30 - 150	YES	-
13C12 - 1,2,3,4,7,8-HxCDD	96	50 - 130	30 - 150	YES	-
13C12 - 1,2,3,6,7,8-HxCDD	97	50 - 130	30 - 150	YES	-
13C12 - 1,2,3,4,6,7,8-HpCDD	85	40 - 130	20 - 150	YES	-
13C12 - OCDD	100	40 - 130	20 - 150	YES	-
PCDFs					
13C12 - 2,3,7,8-TCDF	96	50 - 130	30 - 150	YES	-
13C12 - 2,3,4,7,8-PeCDF	60	50 - 130	30 - 150	YES	-
13C12 - 1,2,3,4,7,8-HxCDF	77	50 - 130	30 - 150	YES	-
13C12 - 1,2,3,6,7,8-HxCDF	94	50 - 130	30 - 150	YES	-
13C12 - 2,3,4,6,7,8-HxCDF	93	50 - 130	30 - 150	YES	-
13C12 - 1,2,3,4,6,7,8-HpCDF	96	40 - 130	20 - 150	YES	-
13C12 - OCDF	78	40 - 130	20 - 150	YES	-
Sampling standard	Recovery [%]	Acceptable range [%]		Rec. in range?	
13C12-1,2,3,7,8-PeCDF	93	> 50		YES	
13C12-1,2,3,7,8,9-HxCDF	91	> 50		YES	
13C12-1,2,3,4,7,8,9-HpCDF	74	> 50		YES	

Test Report No PW/61/07/24

Attachment no. 3 to the Certificate of Analysis for work order PR2469525

Sample: P/47/06/24

ALS SAMPLE ID: PR2469525/ 001

Measurement results PCBs:

Sample:		P/47/06/24			
		Final extract [µl]:	250		
		Injection volume [µl]:	4		
		Acquisition date [d.m.y h:m]:	18.6.24 7:06		
PCBs	Result [ng/sample]	Limit of Detection [ng/sample]	Limit of Quantification [ng/sample]	⁴ WHO-TEF ₅	WHO-TEQ Upperbound [ng/sample]
PCB #77	< 0.097	0.026	0.097	0.0001	0.0000097
PCB #81	< 0.034	0.034	0.11	0.0003	0.00001
PCB #126	< 0.042	0.042	0.14	0.1	0.0042
PCB #169	< 0.042	0.042	0.14	0.03	0.0013
PCB #105	< 0.8	0.067	0.8	0.00003	0.000024
PCB #114	< 0.039	0.039	0.13	0.00003	0.0000012
PCB #118	< 0.68	0.041	0.68	0.00003	0.00002
PCB #123	< 0.05	0.05	0.17	0.00003	0.0000015
PCB #156	< 0.097	0.044	0.097	0.00003	0.0000029
PCB #157	< 0.047	0.047	0.16	0.00003	0.0000014
PCB #167	< 0.11	0.032	0.11	0.00003	0.0000032
PCB #170	< 0.37	0.037	0.37	-	0
PCB #180	< 0.66	0.034	0.66	-	0
PCB #189	< 0.026	0.026	0.088	0.00003	0.00000079
WHO-TEQ from quantified PCBs - ² Lowerbound ²					0
WHO-TEQ from PCBs - „Mediumbound ³ ”					0.0028
Maximum possible WHO-TEQ - ² Upperbound ²					0.0055
PCBs	Result [ng/sample]	Limit of Detection [ng/sample]	Limit of Quantification [ng/sample]	Indicator PCB Lowerbound [ng/sample]	Indicator PCB Upperbound [ng/sample]
PCB #28	< 1.5	0.084	1.5	0	1.5
PCB #52	< 0.59	0.03	0.59	0	0.59
PCB #101	< 0.82	0.067	0.82	0	0.82
PCB #118	< 0.68	0.041	0.68	0	0.68
PCB #138	< 1.1	0.08	1.1	0	1.1
PCB #153	< 1.1	0.072	1.1	0	1.1
PCB #180	< 0.66	0.034	0.66	0	0.66
Indicator PCB6 - ² Lowerbound ²				0	
Maximal possible Indicator PCB6 - ² Upperbound ²					5.9
Indicator PCB7 - ² Lowerbound ²				0	
Maximal possible Indicator PCB7 - ² Upperbound ²					6.5

⁴WHO 2005 TEF according to Van den Berg et al: Toxicological Sciences Advance Acces, 7 July 2006

Limits of quantification are defined on the base of blank level.

The limit of detection is defined as the amount of analyte producing a signal with $S/N \geq 3$.

The value of the detection limit is mentioned as the actual value at the acquisition date.

Measurement uncertainty is expressed as a double ($k=2$) relative standard deviation (RSD%), and corresponds to 95% confidence interval.

Estimation of uncertainty of each PCB congener is 30% , total WHO-TEQ and PCB6/PCB7 is 20%.

These values were ensured by analyses of certified reference material under conditions of internal reproducibility.

Results marked "<" are lower than the limit of detection or quantification.

²Lowerbound² and ²Upperbound² are levels defined in Regulation 2017/644 and EN 1948-4.

³Mediumbound³ is level defined in Regulation 2017/644.

Test Report No PW/61/07/24

Attachment no. 3 to the Certificate of Analysis for work order PR2469525

Sample: P/47/06/24		Final extract [µl]:	250
		Injection volume [µl]:	4
		Acquisition date [d.m.y h:m]:	18.6.24 7:06
Sampling standard	Recovery [%]	Acceptable range [%]	Rec. in range?
13C12-2,3,4,4'-tetraCB (60)	63	> 50	YES
13C12-2,3,3',4,5,5'-hexaCB (159)	55	> 50	YES

Test Report No PW/61/07/24**9. CERTIFICATE OF ACCREDITATION****POLSKIE CENTRUM AKREDYTACJI**
POLISH CENTRE FOR ACCREDITATIONSygnatariusz EA MLA
EA MLA Signatory**CERTYFIKAT AKREDYTACJI**
LABORATORIUM BADAWCZEGO
ACCREDITATION CERTIFICATE OF TESTING LABORATORY
Nr AB 994

Potwierdza się, że: / This is to confirm that:

„PROFTECH” Sp. z o.o.
ul. Kurta Aldera 44, 41-506 Chorzówspełnia wymagania normy PN-EN ISO/IEC 17025:2018-02
meets requirements of the PN-EN ISO/IEC 17025:2018-02 standardAkredytowana działalność jest określona w Zakresie Akredytacji Nr AB 994
Accredited activity is defined in the Scope of Accreditation No AB 994Akredytacja pozostaje w mocy pod warunkiem przestrzegania
wymagań jednostki akredytującej określonych w kontrakcie Nr AB 994
This accreditation remains in force provided the Laboratory observes
the requirements of Accreditation Body defined in the Contract No AB 994Akredytacji udzielono dnia 30.01.2009 r.
Accreditation was granted on 30.01.2009DYREKTOR
PÓLSKIEGO CENTRUM AKREDYTACJI

LUCYNA OLBORSKA

Warszawa, dnia 9 grudnia 2019 roku

Test Report No PW/61/07/24

10. MEASUREMENT PLANE SCHEME

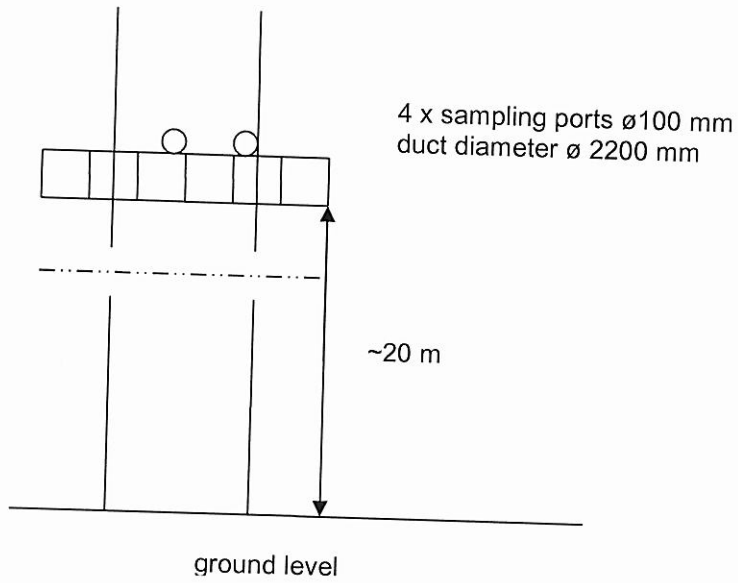

DYREKTOR

Approved by
Inz. Dariusz Guja

.....
Name and Signature

END OF REPORT

